

Quasisymmetries of Finitely Ramified Julia Sets

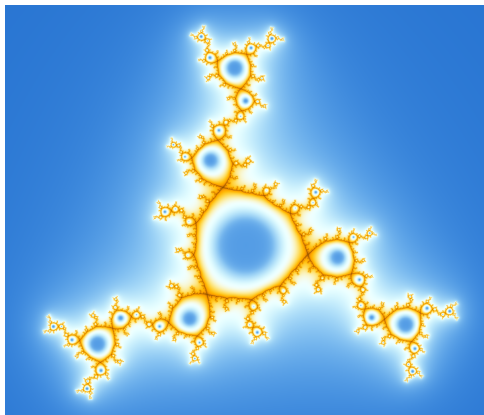

Jim Belk, University of Glasgow

Quasiworld, 4 June 2026

Joint Work



Bradley Forrest
Stockton University

Quasisymmetries

Quasisymmetries

Let X and Y be metric spaces.

Definition (Tukia and Väisälä (1980))

A homeomorphism $f: X \rightarrow Y$ is a **quasisymmetry** if there exists a homeomorphism $\eta: [0, \infty) \rightarrow [0, \infty)$ such that

$$\frac{d(f(a), f(b))}{d(f(a), f(c))} \leq \eta\left(\frac{d(a, b)}{d(a, c)}\right)$$

for every triple a, b, c of distinct points in X .

Note: The quasisymmetries $X \rightarrow X$ form a group.

Quasiconformal vs. Quasisymmetric

Theorem (Väisälä 1981)

A quasiconformal homeomorphism between domains in \mathbb{R}^n restricts to a quasisymmetry on every compact set.

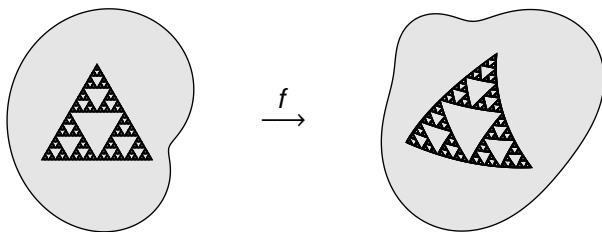

Väisälä also proved a sort of converse to this, known as the “egg yolk principle”.

Some Basic Examples

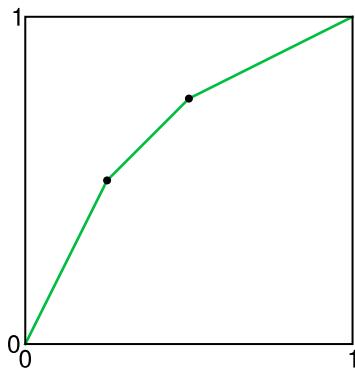

$$\frac{d(f(a), f(b))}{d(f(a), f(c))} \leq \eta\left(\frac{d(a, b)}{d(a, c)}\right)$$

If f is bilipschitz with

$$\frac{1}{K} d(x, x') \leq d(f(x), f(x')) \leq K d(x, x')$$

then f is quasisymmetric, with $\eta(t) = K^2 t$.

Some Basic Examples

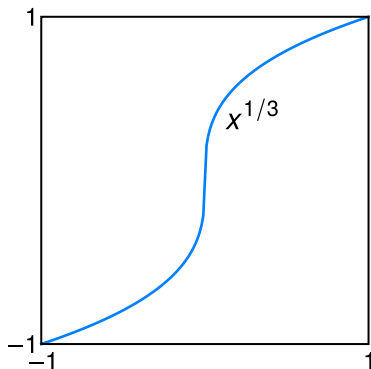

$$\frac{d(f(a), f(b))}{d(f(a), f(c))} \leq \eta \left(\frac{d(a, b)}{d(a, c)} \right)$$

The function $f(x) = x^{1/3}$ is a quasisymmetry of $[-1, 1]$, with

$$\eta(t) = \begin{cases} 6t^{1/3} & \text{if } 0 \leq t \leq 1 \\ 6t & \text{if } t > 1. \end{cases}$$

A Non-Example

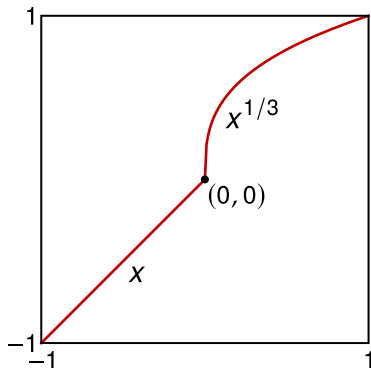

$$\frac{d(f(a), f(b))}{d(f(a), f(c))} \leq \eta \left(\frac{d(a, b)}{d(a, c)} \right)$$

This piecewise function is **not** a quasisymmetry of $[-1, 1]$.

A Less Basic Example

Theorem (Bonk–Schramm 2000)

Any quasi-isometry $G \rightarrow H$ between hyperbolic groups induces a quasisymmetry $\partial_\infty G \rightarrow \partial_\infty H$.

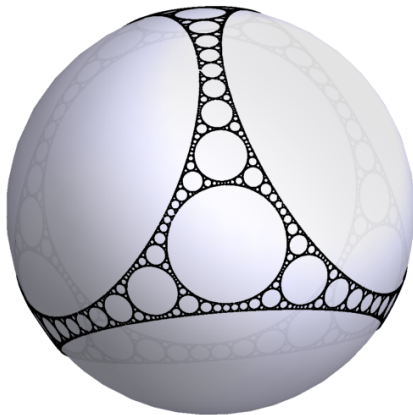

A Less Basic Example

Theorem (Bonk–Schramm 2000)

Any quasi-isometry $G \rightarrow H$ between hyperbolic groups induces a quasisymmetry $\partial_\infty G \rightarrow \partial_\infty H$.

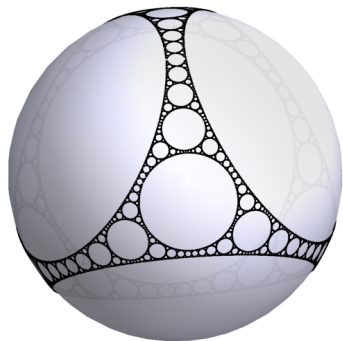

$\partial_\infty G$

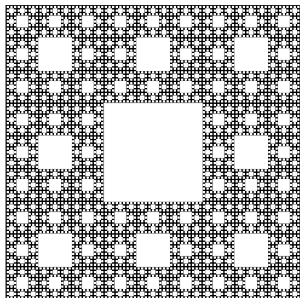

Sierpiński carpet

Cannon's Conjecture

Let G be a hyperbolic group.

Cannon's Conjecture (1994)

If there exists a homeomorphism $\partial_\infty G \rightarrow S^2$, then G acts geometrically on \mathbb{H}^3 .

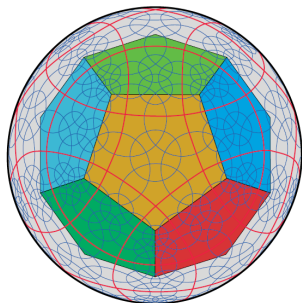

figure from Cannon, Floyd, and Parry 2001

Cannon's Conjecture

Let G be a hyperbolic group.

Cannon's Conjecture (1994)

If there exists a homeomorphism $\partial_\infty G \rightarrow S^2$, then G acts geometrically on \mathbb{H}^3 .

Cannon's Conjecture

Let G be a hyperbolic group.

Cannon's Conjecture (1994)

If there exists a homeomorphism $\partial_\infty G \rightarrow S^2$, then G acts geometrically on \mathbb{H}^3 .

Theorem (Sullivan–Tukia 1986)

*If there exists a **quasisymmetry** $\partial_\infty G \rightarrow S^2$ then G acts geometrically on \mathbb{H}^3 .*

By the Way

Theorem (Dahmani–Guirardel–Przytycki 2011)

The boundary of a “random” hyperbolic group is homeomorphic to the Menger sponge.

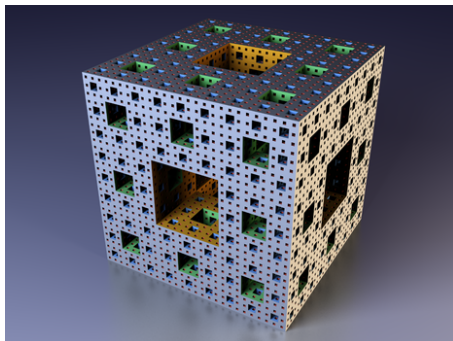
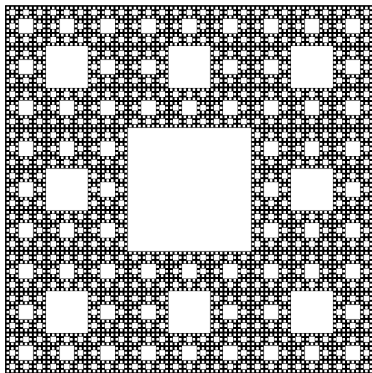

figure by Niabot from Wikimedia Commons

Quasisymmetries of Fractals

Quasisymmetries of Sierpiński Carpets

We want to understand quasisymmetries for various fractals, e.g. the Sierpiński carpet.



Quasisymmetries of Sierpiński Carpets

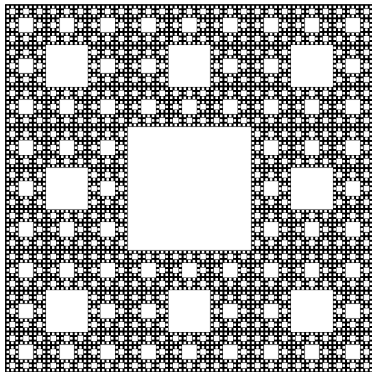

Quasisymmetries of Sierpiński Carpets

Theorem (Bonk–Merenkov 2013)

The quasisymmetry group of the square Sierpiński carpet is dihedral of order 8.

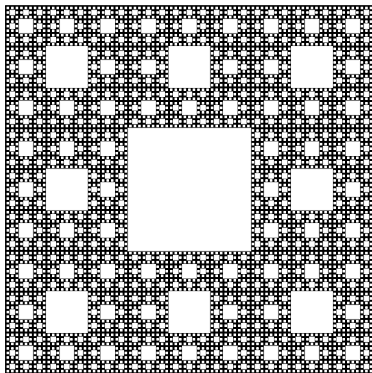

Quasisymmetries of Sierpiński Carpets

Theorem (Bonk–Merenkov 2013)

The quasisymmetry group of the square Sierpiński carpet is dihedral of order 8.

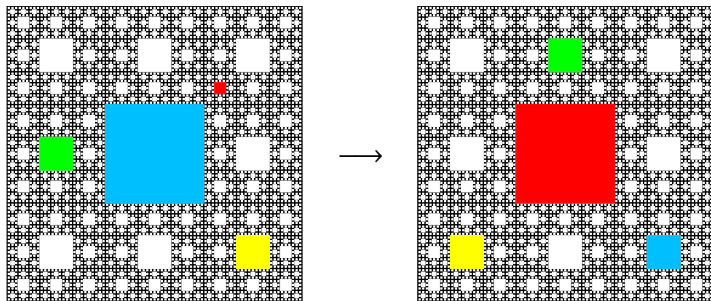

The full homeomorphism group is very large.

Quasisymmetries of Sierpiński Carpets

Other Sierpiński carpets can have many quasisymmetries.

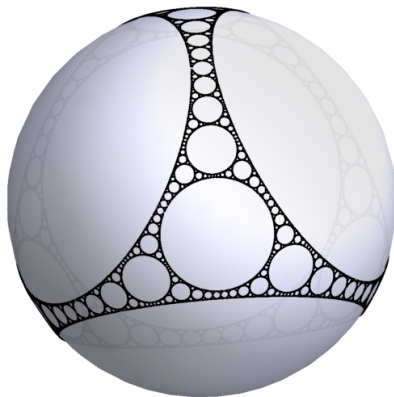

So the quasisymmetry group depends on the metric.

Sierpiński Carpet Julia Sets

Sierpiński carpets also arise as Julia sets for certain rational functions (Milnor–Lei 1993).

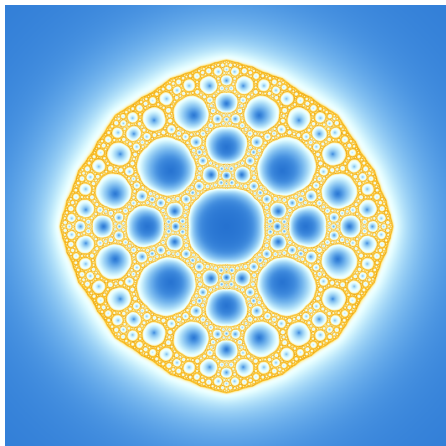

$$f(z) = z^2 - \frac{1}{16z^2}$$

Julia Sets

Every rational function on the Riemann sphere has a **Julia set** (the closure of the repelling periodic points).

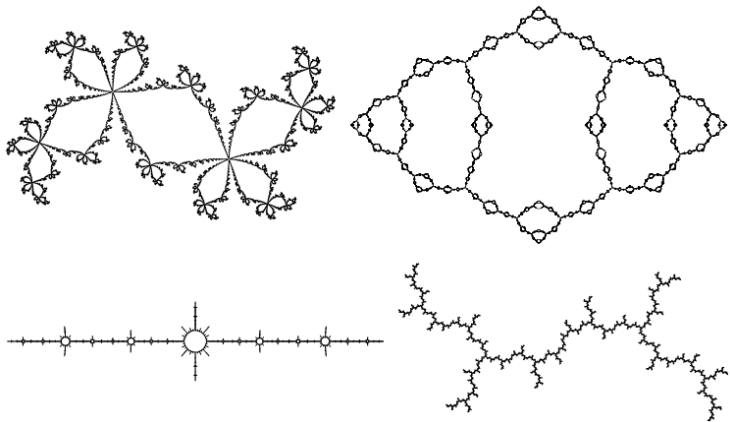

Sierpiński Carpet Julia Sets

Sierpiński carpets also arise as Julia sets for certain rational functions (Milnor–Lei 1993).

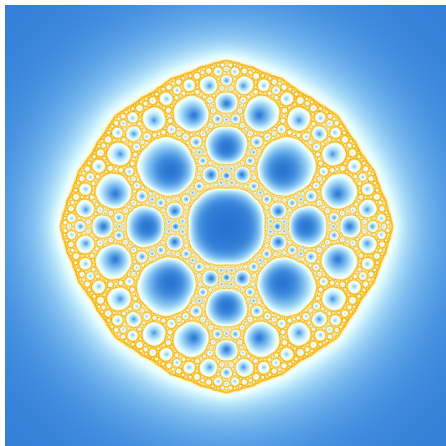

$$f(z) = z^2 - \frac{1}{16z^2}$$

Sierpiński Carpet Julia Sets

Sierpiński carpets also arise as Julia sets for certain rational functions (Milnor–Lei 1993).

Theorem (Bonk–Lyubich–Merenkov 2016)

Let $f(z)$ be a rational function whose Julia set J_f is a Sierpiński carpet. If f is postcritically finite, then the quasimetry group of J_f is finite.

Qiu, Yang, and Zeng (2019) extend this to a large family of semi-hyperbolic Sierpiński carpet Julia sets.

The Basilica

The **basilica** is the Julia set for $f(z) = z^2 - 1$.

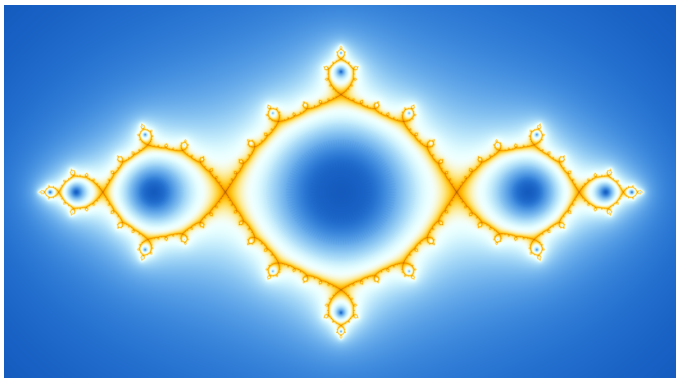

The Basilica

The **basilica** is the Julia set for $f(z) = z^2 - 1$.

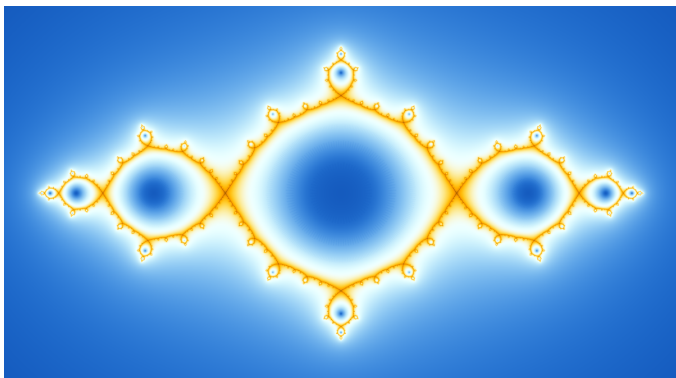

Theorem (Lyubich–Merenkov 2018)

The quasimetry group of the basilica is infinite.

Other Examples

Subsequent work has established that certain other Julia sets also have infinitely many quasisymmetries.

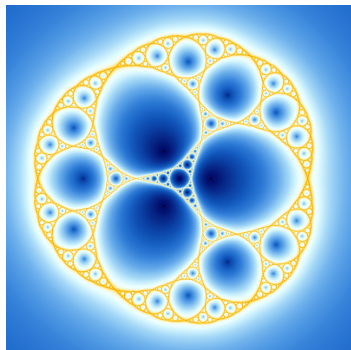

Lodge–Lyubich–Merenkov–
Mukherjee (2023)

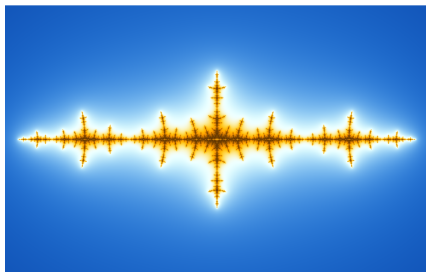

Alland (2023)

Quasisymmetries of the Basilica

Thompson's Group T

Thompson's group T is the group of all piecewise-linear homeomorphisms of the circle \mathbb{R}/\mathbb{Z} for which:

1. All slopes are powers of 2, and
2. All breakpoints are dyadic rationals, as is the image of 0.

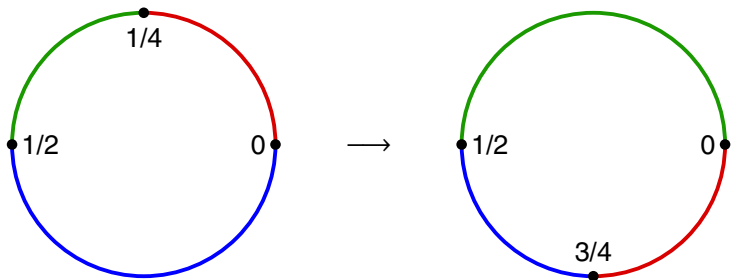

Thompson's Group T

Thompson's group T is the group of all piecewise-linear homeomorphisms of the circle \mathbb{R}/\mathbb{Z} for which:

1. All slopes are powers of 2, and
2. All breakpoints are dyadic rationals, as is the image of 0.

Thompson's Group T

Thompson's group T is the group of all piecewise-linear homeomorphisms of the circle \mathbb{R}/\mathbb{Z} for which:

1. All slopes are powers of 2, and
2. All breakpoints are dyadic rationals, as is the image of 0.

Properties of T :

1. (Thompson 1965) T is infinite, finitely presented, and simple.
2. (Brown 1987) T has type F_∞ .
3. (Farley 2005) T acts properly by isometries on a CAT(0) cubical complex.
4. (B-Matucci 2014) T has solvable conjugacy problem.

The Basilica Thompson Group

In 2015, Bradley Forrest and I described a natural action of T on the basilica.

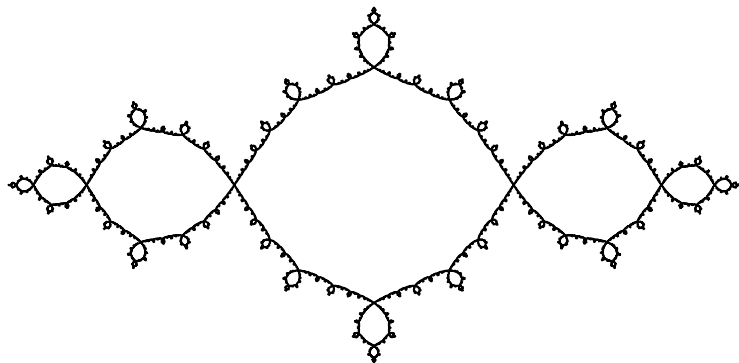

The Basilica Thompson Group

In 2015, Bradley Forrest and I described a natural action of T on the basilica.

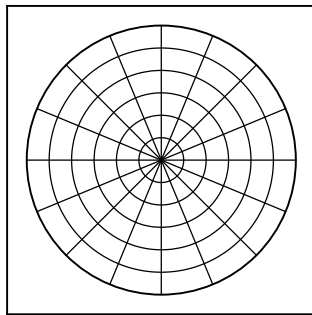
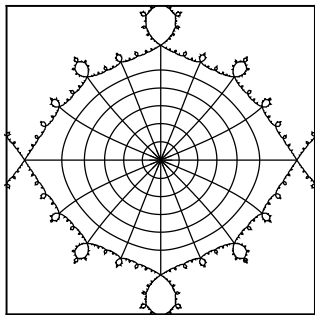

The Basilica Thompson Group

In 2015, Bradley Forrest and I described a natural action of T on the basilica.

Domain:

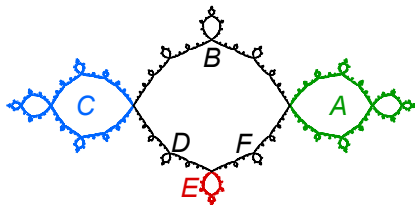

Range:

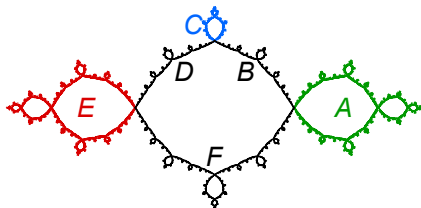

The Basilica Thompson Group

In 2015, Bradley Forrest and I described a natural action of T on the basilica.

This T is contained in a larger group of piecewise-conformal homeomorphisms that we called the ***basilica Thompson group***.

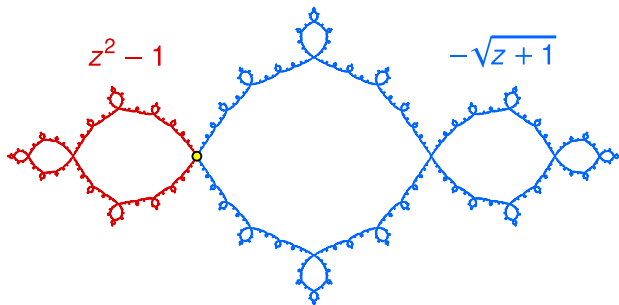

Properties of the Basilica Thompson Group

1. (B–Forrest 2015) The basilica Thompson group is finitely generated, co-embeddable with T , and has an index-two subgroup which is simple.
2. (Witzel–Zaremsky 2019) The basilica Thompson group is not finitely presented.
3. (Tarocchi 2023) The basilica Thompson group has solvable conjugacy problem.

Properties of the Basilica Thompson Group

1. (B–Forrest 2015) The basilica Thompson group is finitely generated, co-embeddable with T , and has an index-two subgroup which is simple.
2. (Witzel–Zaremsky 2019) The basilica Thompson group is not finitely presented.
3. (Tarocchi 2023) The basilica Thompson group has solvable conjugacy problem.

Theorem (Lyubich–Merenkov 2018)

Every element of the basilica Thompson group is a quasimetry of the basilica.

Quasisymmetries of the Basilica

Their proof uses the Thurston invariant lamination for the basilica.

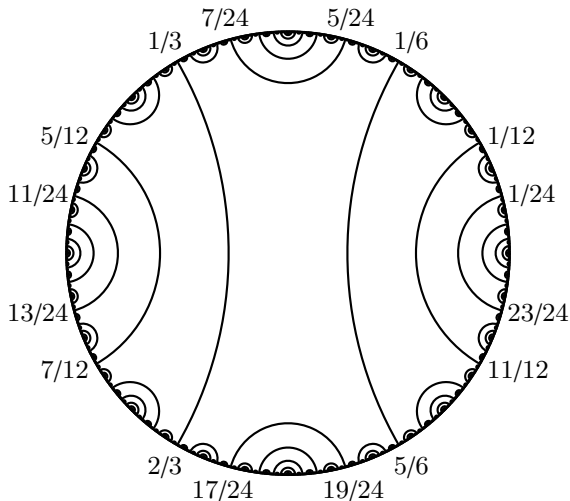

Quasisymmetries of the Basilica

It depends on the fact that there are only countably many arcs.

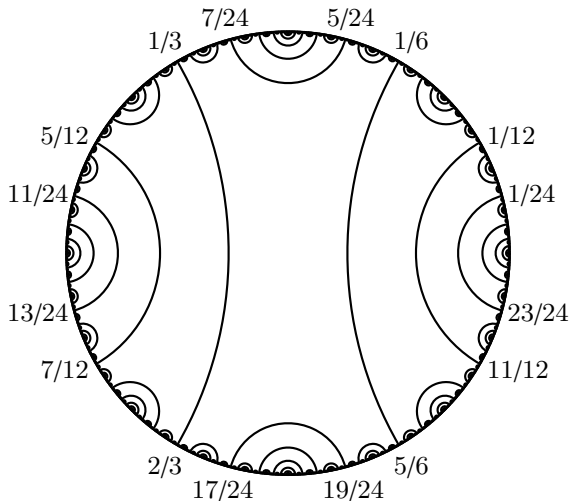

Other Julia Sets

Can we generalize this to other Julia sets?

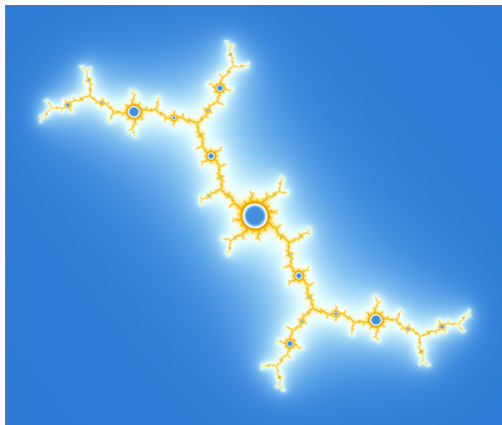

Julia set for $f(z) = z^2 - 0.157 + 1.032i$

Finitely Ramified Fractals

Finitely Ramified Fractals

Roughly speaking, a fractal is ***finitely ramified*** if it is made from pieces (called ***cells***) that have finitely many boundary points.

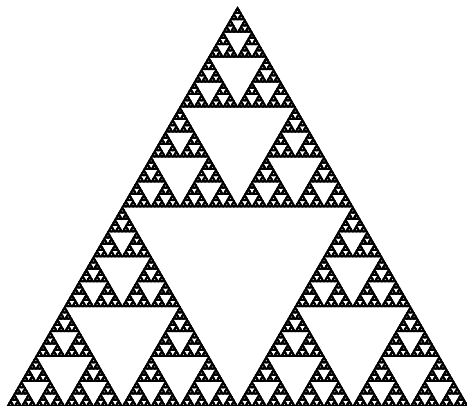

Finitely Ramified Fractals

Roughly speaking, a fractal is ***finitely ramified*** if it is made from pieces (called ***cells***) that have finitely many boundary points.

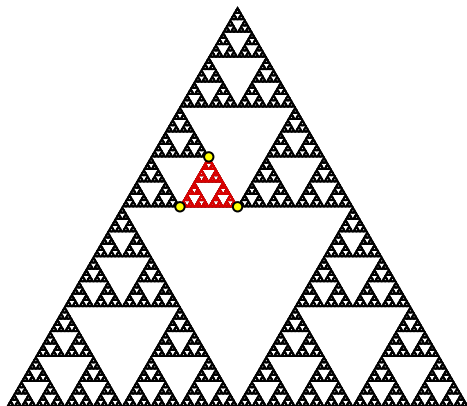

Finitely Ramified Fractals

Roughly speaking, a fractal is ***finitely ramified*** if it is made from pieces (called ***cells***) that have finitely many boundary points.

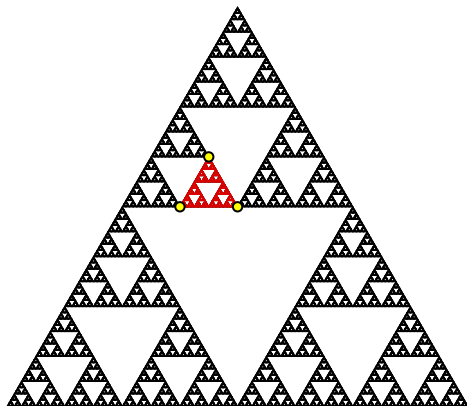

Finitely ramified

Finitely Ramified Fractals

Roughly speaking, a fractal is ***finitely ramified*** if it is made from pieces (called ***cells***) that have finitely many boundary points.

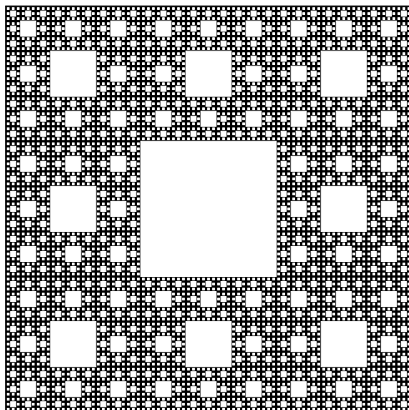

Finitely Ramified Fractals

Roughly speaking, a fractal is ***finitely ramified*** if it is made from pieces (called ***cells***) that have finitely many boundary points.

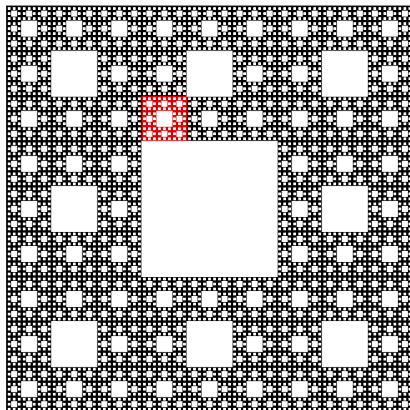

Finitely Ramified Fractals

Roughly speaking, a fractal is **finitely ramified** if it is made from pieces (called **cells**) that have finitely many boundary points.

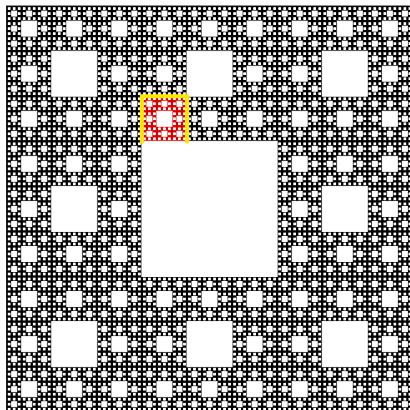

Not finitely ramified

General Definition

Definition (Teplyaev 2008)

Let X be a compact, connected metrizable space.

General Definition

Definition (Teplyaev 2008)

Let X be a compact, connected metrizable space.

For each $n \geq 0$, fix a finite collection of subsets of X (the ***n*-cells**).

General Definition

Definition (Teplyaev 2008)

Let X be a compact, connected metrizable space.

For each $n \geq 0$, fix a finite collection of subsets of X (the ***n*-cells**).

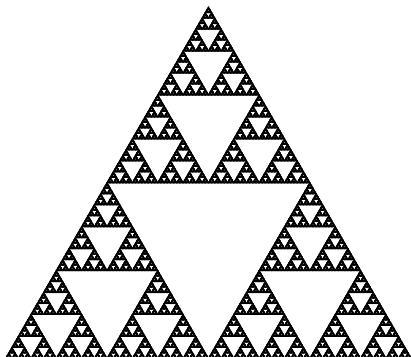

General Definition

Definition (Teplyaev 2008)

Let X be a compact, connected metrizable space.

For each $n \geq 0$, fix a finite collection of subsets of X (the **n -cells**).

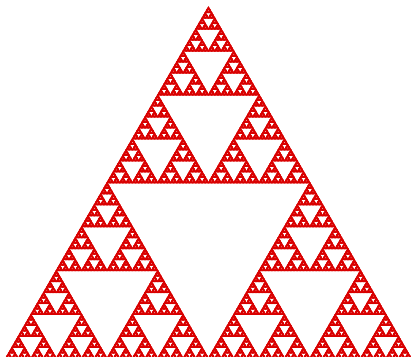

One 0-cell

General Definition

Definition (Teplyaev 2008)

Let X be a compact, connected metrizable space.

For each $n \geq 0$, fix a finite collection of subsets of X (the ***n*-cells**).

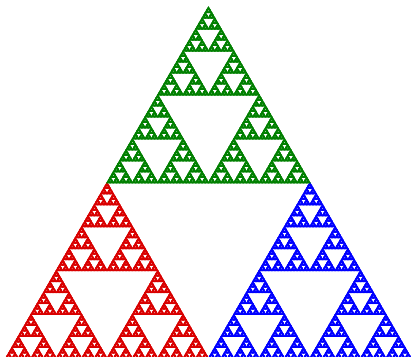

Three 1-cells

General Definition

Definition (Teplyaev 2008)

Let X be a compact, connected metrizable space.

For each $n \geq 0$, fix a finite collection of subsets of X (the ***n*-cells**).

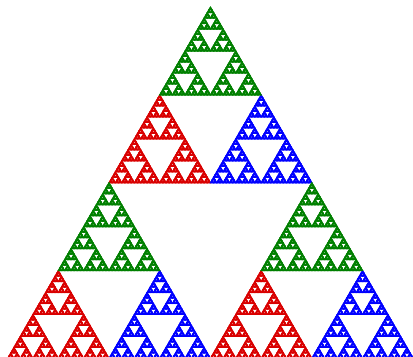

Nine 2-cells

General Definition

Definition (Teplyaev 2008)

Let X be a compact, connected metrizable space.

For each $n \geq 0$, fix a finite collection of subsets of X (the ***n*-cells**).

General Definition

Definition (Teplyaev 2008)

Let X be a compact, connected metrizable space.

For each $n \geq 0$, fix a finite collection of subsets of X (the ***n*-cells**).

These define a ***finitely ramified fractal*** if:

- 1.
- 2.
- 3.
- 4.

General Definition

Definition (Teplyaev 2008)

Let X be a compact, connected metrizable space.

For each $n \geq 0$, fix a finite collection of subsets of X (the ***n*-cells**).

These define a ***finitely ramified fractal*** if:

1. Each n -cell is compact, connected, and has nonempty interior.
- 2.
- 3.
- 4.

General Definition

Definition (Teplyaev 2008)

Let X be a compact, connected metrizable space.

For each $n \geq 0$, fix a finite collection of subsets of X (the ***n*-cells**).

These define a ***finitely ramified fractal*** if:

1. Each n -cell is compact, connected, and has nonempty interior.
2. The intersection of any two n -cells is finite.
- 3.
- 4.

General Definition

Definition (Teplyaev 2008)

Let X be a compact, connected metrizable space.

For each $n \geq 0$, fix a finite collection of subsets of X (the ***n*-cells**).

These define a ***finitely ramified fractal*** if:

1. Each n -cell is compact, connected, and has nonempty interior.
2. The intersection of any two n -cells is finite.
3. The entire space X is the unique 0-cell, and every n -cell is a union of $(n + 1)$ -cells.
- 4.

General Definition

Definition (Teplyaev 2008)

Let X be a compact, connected metrizable space.

For each $n \geq 0$, fix a finite collection of subsets of X (the ***n*-cells**).

These define a ***finitely ramified fractal*** if:

1. Each n -cell is compact, connected, and has nonempty interior.
2. The intersection of any two n -cells is finite.
3. The entire space X is the unique 0-cell, and every n -cell is a union of $(n + 1)$ -cells.
4. If $E_0 \supseteq E_1 \supseteq E_2 \supseteq \cdots$ with each E_n an n -cell, then $\bigcap_{n=0} E_n$ is a single point.

Example: The Basilica

The basilica Julia set can be viewed as a finitely ramified fractal.

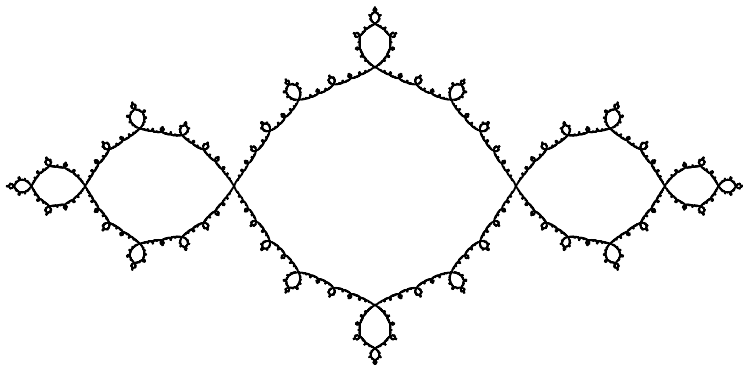

Example: The Basilica

The basilica Julia set can be viewed as a finitely ramified fractal.

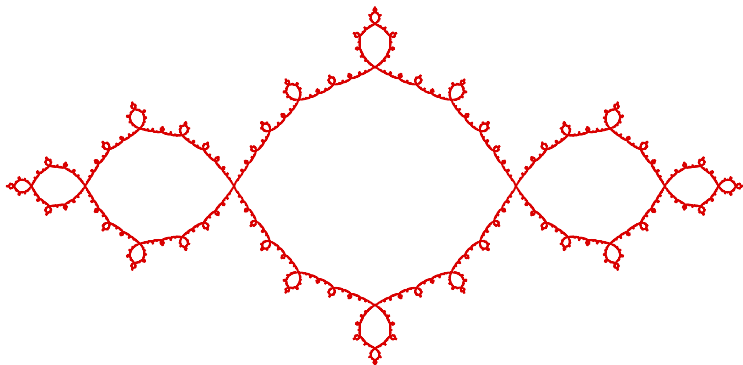

One 0-cell

Example: The Basilica

The basilica Julia set can be viewed as a finitely ramified fractal.

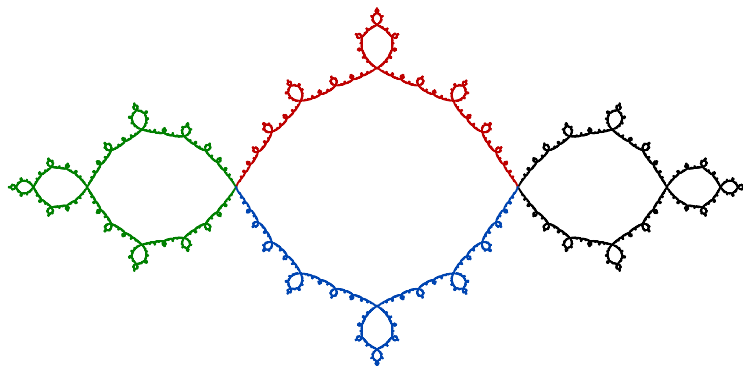

Four 1-cells

Example: The Basilica

The basilica Julia set can be viewed as a finitely ramified fractal.

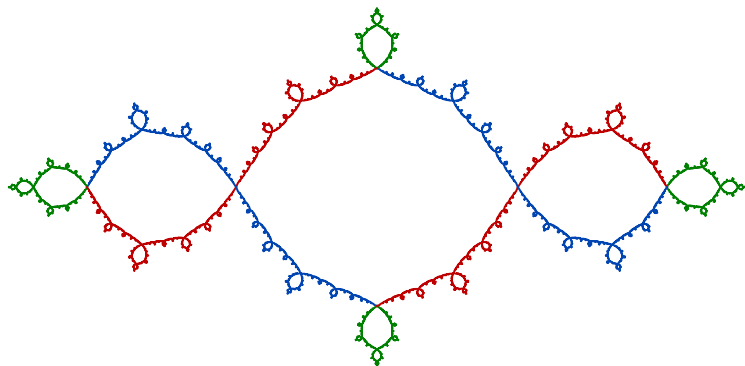

Twelve 2-cells

Example: The Basilica

The basilica Julia set can be viewed as a finitely ramified fractal.

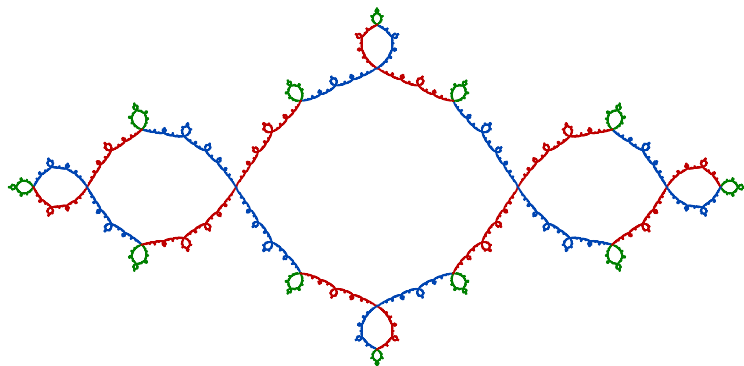

Thirty-six 3-cells

Finitely Ramified Julia Sets

Julia sets for polynomials tend to be finitely ramified.

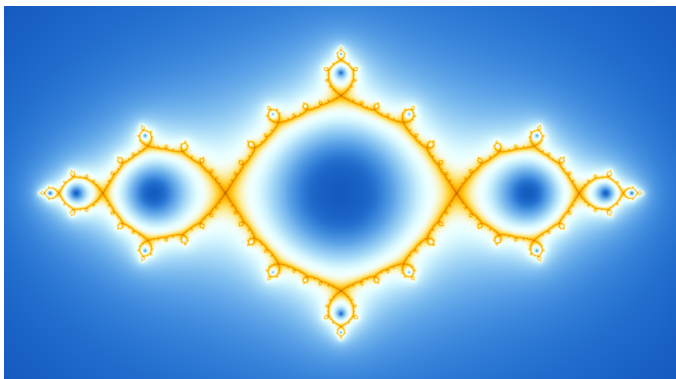

Julia set for $f(z) = z^2 - 1$

Finitely Ramified Julia Sets

Julia sets for polynomials tend to be finitely ramified.

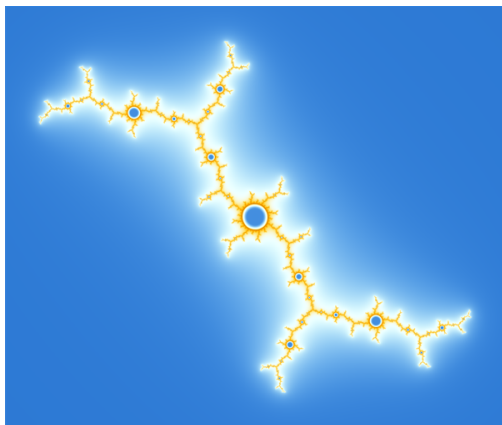

Julia set for $f(z) = z^2 - 0.157 + 1.032i$

Finitely Ramified Julia Sets

Julia sets for polynomials tend to be finitely ramified.

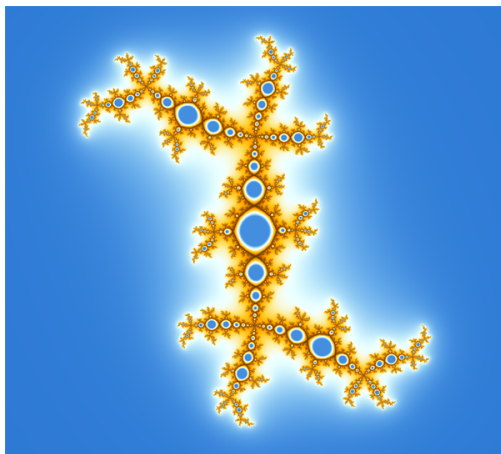

Julia set for $f(z) = z^2 + 0.32 + 0.56i$

Finitely Ramified Julia Sets

Julia sets for polynomials tend to be finitely ramified.

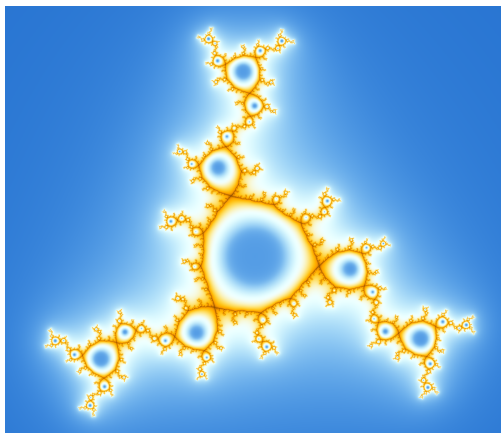

Julia set for $f(z) = z^3 - 0.21 + 1.09i$

Finitely Ramified Julia Sets

Julia sets for rational functions are sometimes finitely ramified.

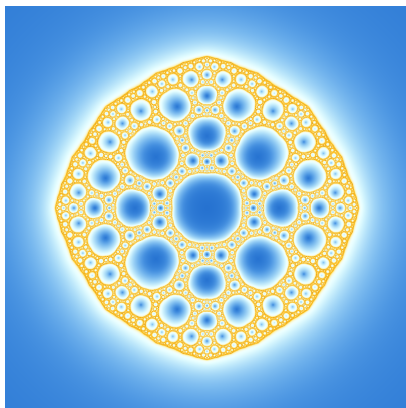

$$\text{Julia set for } f(z) = z^2 - \frac{1}{16z^2}$$

Finitely Ramified Julia Sets

Julia sets for rational functions are sometimes finitely ramified.

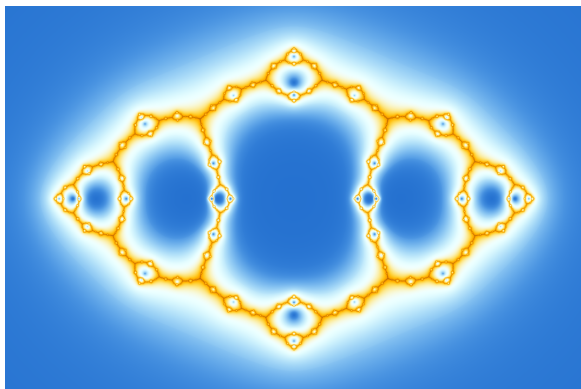

Julia set for $f(z) = \frac{1}{z^2} - 1$

Finitely Ramified Julia Sets

Julia sets for rational functions are sometimes finitely ramified.

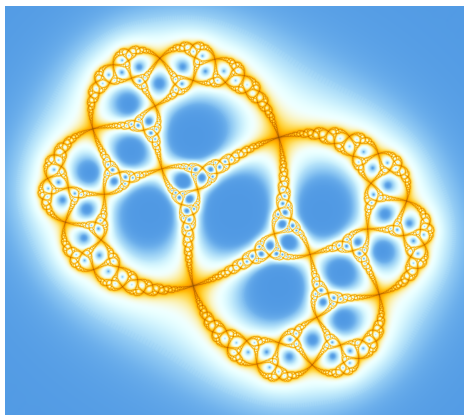

$$\text{Julia set for } f(z) = \frac{e^{2\pi i/3}z^2 - 1}{z^2 - 1}$$

Finitely Ramified Julia Sets

Idea: We should expect finitely ramified Julia sets to have lots of quasisymmetries.

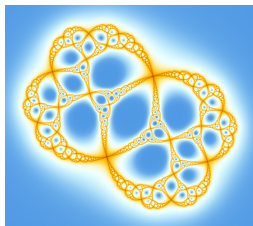
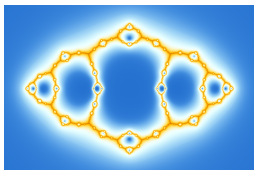
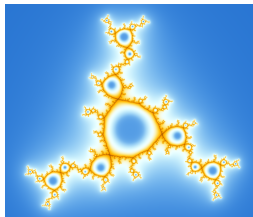
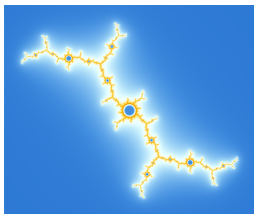

Finitely Ramified Julia Sets

Idea: We should expect finitely ramified Julia sets to have lots of quasisymmetries.

Finitely Ramified Julia Sets

Idea: We should expect finitely ramified Julia sets to have lots of quasiconformal maps.

Theorem (B–Forrest 2025)

The following Julia sets have infinitely many quasiconformal maps:

1. *All connected Julia sets for hyperbolic quadratic polynomials.*
2. *Many Julia sets for higher-degree hyperbolic polynomials.*
3. *The Julia set for the rational function $f(z) = \frac{1}{z^2} - 1$*

Undistorted Metrics

Undistorted Metrics

A metric on a finitely ramified fractal X is ***undistorted*** if:

1. It has exponential cell decay, and
2. The cells have uniform relative separation.

Undistorted Metrics

A metric on a finitely ramified fractal X is **undistorted** if:

1. It has exponential cell decay, and
2. The cells have uniform relative separation.

Exponential Cell Decay:

There exist constants $0 < r < R < 1$ and $C \geq 1$ so that

$$\frac{r^{|m-n|}}{C} \leq \frac{\text{diam}(E')}{\text{diam}(E)} \leq CR^{|m-n|}$$

for any m -cell E and n -cell E' that intersect.

Undistorted Metrics

A metric on a finitely ramified fractal X is ***undistorted*** if:

1. It has exponential cell decay, and
2. The cells have uniform relative separation.

Undistorted Metrics

A metric on a finitely ramified fractal X is ***undistorted*** if:

1. It has exponential cell decay, and
2. The cells have **uniform relative separation**.

Uniform Relative Separation:

There exists a constant $\delta > 0$ so that

$$d(E, E') \geq \delta \operatorname{diam}(E)$$

for any two n -cells E and E' that are disjoint.

Undistorted Metrics

A metric on a finitely ramified fractal X is ***undistorted*** if:

1. It has exponential cell decay, and
2. The cells have uniform relative separation.

Undistorted Metrics

A metric on a finitely ramified fractal X is ***undistorted*** if:

1. It has exponential cell decay, and
2. The cells have uniform relative separation.

Undistorted Metrics Theorem (B–Forrest 2025)

1. *All undistorted metrics on X are quasisymmetrically equivalent.*
2. *Any metric quasisymmetrically equivalent to an undistorted metric is undistorted.*

Undistorted Metrics

A metric on a finitely ramified fractal X is ***undistorted*** if:

1. It has exponential cell decay, and
2. The cells have uniform relative separation.

Undistorted Metrics Theorem (B–Forrest 2025)

1. *All undistorted metrics on X are quasisymmetrically equivalent.*
2. *Any metric quasisymmetrically equivalent to an undistorted metric is undistorted.*

That is, the undistorted metrics on X are a ***quasisymmetric gauge***, determined only by the topology and cell structure.

Undistorted Metrics

A metric on a finitely ramified fractal X is ***undistorted*** if:

1. It has exponential cell decay, and
2. The cells have uniform relative separation.

Undistorted Metrics Theorem (B–Forrest 2025)

1. *All undistorted metrics on X are quasisymmetrically equivalent.*
2. *Any metric quasisymmetrically equivalent to an undistorted metric is undistorted.*

Undistorted Metrics

A metric on a finitely ramified fractal X is ***undistorted*** if:

1. It has exponential cell decay, and
2. The cells have uniform relative separation.

Undistorted Metrics Theorem (B–Forrest 2025)

1. *All undistorted metrics on X are quasisymmetrically equivalent.*
2. *Any metric quasisymmetrically equivalent to an undistorted metric is undistorted.*

Corollary for Quasisymmetries

If X and Y have undistorted metrics, a homeomorphism $f : X \rightarrow Y$ is a quasisymmetry if and only if the pullback of the metric on Y is undistorted.

Existence of Undistorted Metrics

Warning: Not every finitely ramified fractal admits an undistorted metric!

Existence of Undistorted Metrics

Warning: Not every finitely ramified fractal admits an undistorted metric!

Existence Theorem (B–Forrest 2025)

A finitely ramified fractal admits an undistorted metric if and only if there exists a k such that:

- 1. Every n -cell contains at least two disjoint $(n + k)$ -cells, and*
- 2. No two disjoint n -cells intersect a common $(n + k)$ -cell.*

Existence of Undistorted Metrics

Warning: Not every finitely ramified fractal admits an undistorted metric!

Existence Theorem (B–Forrest 2025)

A finitely ramified fractal admits an undistorted metric if and only if there exists a k such that:

- 1. Every n -cell contains at least two disjoint $(n + k)$ -cells, and*
- 2. No two disjoint n -cells intersect a common $(n + k)$ -cell.*

Most well-known finitely ramified fractals satisfy these conditions.

Application: Uniformization for Sierpiński Triangles

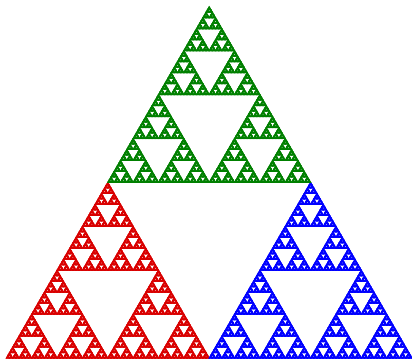

Application: Uniformization for Sierpiński Triangles

Bandt and Retta (1992) proved that the Sierpiński triangle T is **topologically rigid**, i.e. every homeomorphism of T maps n -cells to n -cells.

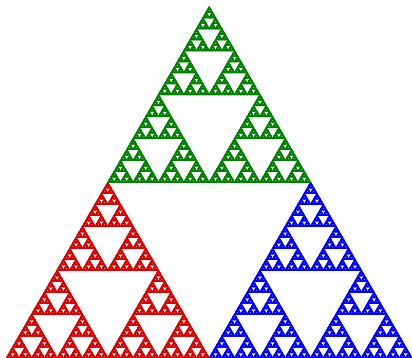

Application: Uniformization for Sierpiński Triangles

Bandt and Retta (1992) proved that the Sierpiński triangle T is **topologically rigid**, i.e. every homeomorphism of T maps n -cells to n -cells.

Application: Uniformization for Sierpiński Triangles

Bandt and Retta (1992) proved that the Sierpiński triangle T is **topologically rigid**, i.e. every homeomorphism of T maps n -cells to n -cells.

Uniformization Theorem (B–Forrest 2025)

A Sierpiński triangle is quasimetrically equivalent to the standard one if and only if its metric is undistorted.

Application: Uniformization for Sierpiński Triangles

Bandt and Retta (1992) proved that the Sierpiński triangle T is **topologically rigid**, i.e. every homeomorphism of T maps n -cells to n -cells.

Uniformization Theorem (B–Forrest 2025)

A Sierpiński triangle is quasimetrically equivalent to the standard one if and only if its metric is undistorted.

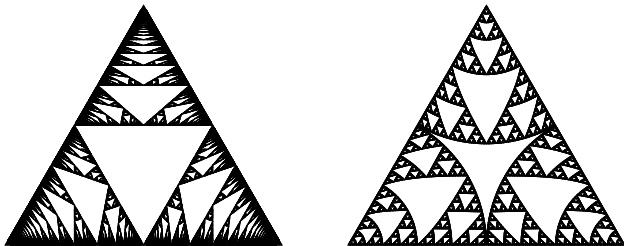

Application: Uniformization for Sierpiński Triangles

Bandt and Retta (1992) proved that the Sierpiński triangle T is **topologically rigid**, i.e. every homeomorphism of T maps n -cells to n -cells.

Uniformization Theorem (B–Forrest 2025)

A Sierpiński triangle is quasimetrically equivalent to the standard one if and only if its metric is undistorted.

Application: Uniformization for Sierpiński Triangles

Bandt and Retta (1992) proved that the Sierpiński triangle T is **topologically rigid**, i.e. every homeomorphism of T maps n -cells to n -cells.

Uniformization Theorem (B–Forrest 2025)

A Sierpiński triangle is quasimetrically equivalent to the standard one if and only if its metric is undistorted.

We obtain a similar uniformization theorem for any topologically rigid fractal.

Applications to Julia Sets

Hyperbolic Rational Functions

A rational function $f(z)$ is **hyperbolic** if the forward orbit of each critical point converges to an attracting cycle.

Such maps are expanding on their Julia set with respect to an appropriate metric.

Hyperbolic Rational Functions

A rational function $f(z)$ is **hyperbolic** if the forward orbit of each critical point converges to an attracting cycle.

Such maps are expanding on their Julia set with respect to an appropriate metric.

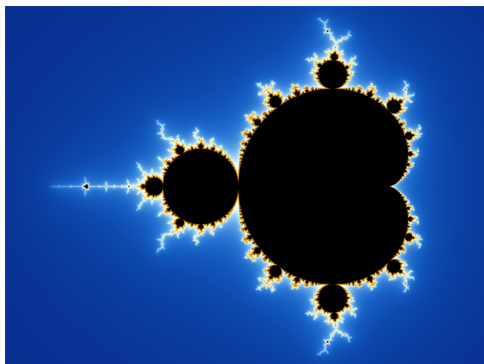

Hyperbolic Rational Functions

A rational function $f(z)$ is **hyperbolic** if the forward orbit of each critical point converges to an attracting cycle.

Such maps are expanding on their Julia set with respect to an appropriate metric.

Hyperbolic Rational Functions

A rational function $f(z)$ is **hyperbolic** if the forward orbit of each critical point converges to an attracting cycle.

Such maps are expanding on their Julia set with respect to an appropriate metric.

All of our results apply only to hyperbolic rational functions f for which the Julia set J_f is connected.

Defining Cells

A set $S \subset J_f$ is a **branch cut** if f^{-1} has a single-valued branch on each component of $J_f \setminus S$.

Defining Cells

A set $S \subset J_f$ is a **branch cut** if f^{-1} has a single-valued branch on each component of $J_f \setminus S$.

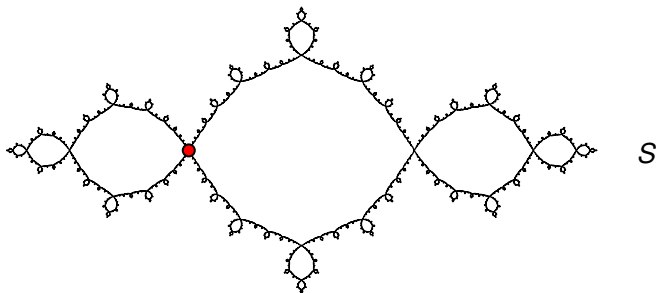

Defining Cells

A set $S \subset J_f$ is a **branch cut** if f^{-1} has a single-valued branch on each component of $J_f \setminus S$.

If S is finite and invariant (i.e. $f(S) \subseteq S$), then the iterated preimages $f^{-n}(S)$ cut J_f into cells.

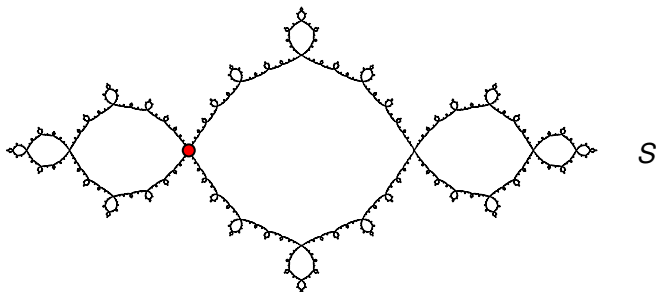

Defining Cells

A set $S \subset J_f$ is a **branch cut** if f^{-1} has a single-valued branch on each component of $J_f \setminus S$.

If S is finite and invariant (i.e. $f(S) \subseteq S$), then the iterated preimages $f^{-n}(S)$ cut J_f into cells.

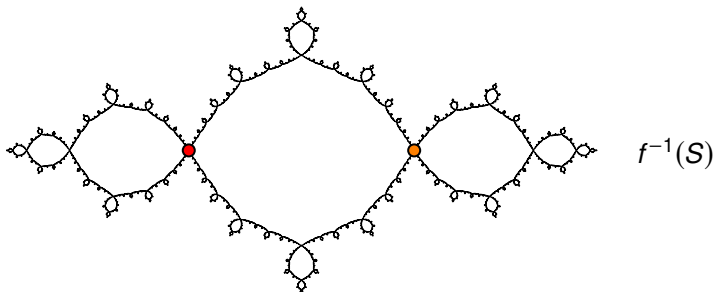

Defining Cells

A set $S \subset J_f$ is a **branch cut** if f^{-1} has a single-valued branch on each component of $J_f \setminus S$.

If S is finite and invariant (i.e. $f(S) \subseteq S$), then the iterated preimages $f^{-n}(S)$ cut J_f into cells.

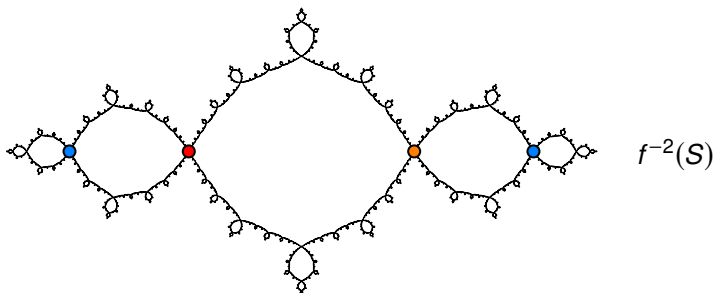

Defining Cells

A set $S \subset J_f$ is a **branch cut** if f^{-1} has a single-valued branch on each component of $J_f \setminus S$.

If S is finite and invariant (i.e. $f(S) \subseteq S$), then the iterated preimages $f^{-n}(S)$ cut J_f into cells.

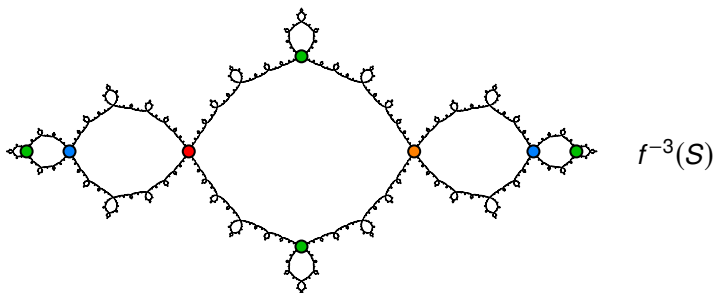

Defining Cells

A set $S \subset J_f$ is a **branch cut** if f^{-1} has a single-valued branch on each component of $J_f \setminus S$.

If S is finite and invariant (i.e. $f(S) \subseteq S$), then the iterated preimages $f^{-n}(S)$ cut J_f into cells.

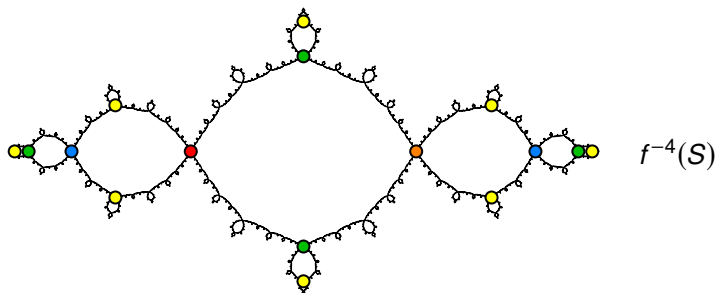

Defining Cells

A set $S \subset J_f$ is a **branch cut** if f^{-1} has a single-valued branch on each component of $J_f \setminus S$.

If S is finite and invariant (i.e. $f(S) \subseteq S$), then the iterated preimages $f^{-n}(S)$ cut J_f into cells.

Defining Cells

A set $S \subset J_f$ is a **branch cut** if f^{-1} has a single-valued branch on each component of $J_f \setminus S$.

If S is finite and invariant (i.e. $f(S) \subseteq S$), then the iterated preimages $f^{-n}(S)$ cut J_f into cells.

Branch Cut Theorem (B–Forrest 2025)

If J_f has a finite invariant branch cut, the resulting cells define a finitely ramified cell structure on J_f , and the restriction of the spherical metric is undistorted.

Defining Cells

A set $S \subset J_f$ is a **branch cut** if f^{-1} has a single-valued branch on each component of $J_f \setminus S$.

If S is finite and invariant (i.e. $f(S) \subseteq S$), then the iterated preimages $f^{-n}(S)$ cut J_f into cells.

Branch Cut Theorem (B–Forrest 2025)

If J_f has a finite invariant branch cut, the resulting cells define a finitely ramified cell structure on J_f , and the restriction of the spherical metric is undistorted.

Proposition (B–Forrest 2025)

If f is a hyperbolic polynomial and J_f is connected, then J_f has a finite invariant branch cut.

Note: Hyperbolic Only!

We **only** prove the branch cut theorem for f hyperbolic.

Branch Cut Theorem (B–Forrest 2025)

If J_f has a finite invariant branch cut, the resulting cells define a finitely ramified cell structure on J_f , and the restriction of the spherical metric is undistorted.

Note: Hyperbolic Only!

We **only** prove the branch cut theorem for f hyperbolic.

Branch Cut Theorem (B–Forrest 2025)

If J_f has a finite invariant branch cut, the resulting cells define a finitely ramified cell structure on J_f , and the restriction of the spherical metric is undistorted.

It would be interesting to extend this to sub-hyperbolic f .

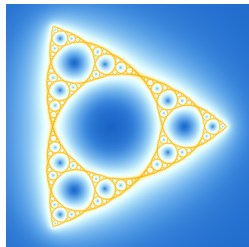
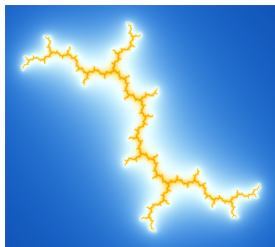

Constructing Quasisymmetries

Constructing Quasisymmetries

Consider two cells in a finitely ramified fractal X :

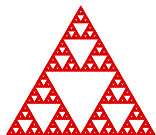

E (m -cell)

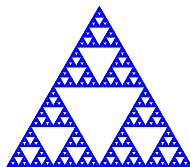

E' (n -cell)

A homeomorphism $E \rightarrow E'$ is **cellular** if it maps $(m + k)$ -cells to $(n + k)$ -cells for all $k \geq 0$.

Constructing Quasisymmetries

A homeomorphism of X is **piecewise-cellular** if there exist subdivisions

$$\{E_1, \dots, E_n\} \quad \text{and} \quad \{E'_1, \dots, E'_n\}$$

of X into cells so that each E_i maps to E'_i by a cellular map.

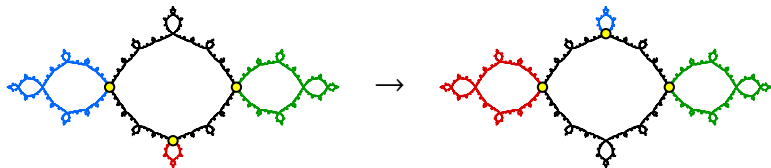

Constructing Quasisymmetries

A homeomorphism of X is ***piecewise-cellular*** if there exist subdivisions

$$\{E_1, \dots, E_n\} \quad \text{and} \quad \{E'_1, \dots, E'_n\}$$

of X into cells so that each E_i maps to E'_i by a cellular map.

Constructing Quasisymmetries

A homeomorphism of X is **piecewise-cellular** if there exist subdivisions

$$\{E_1, \dots, E_n\} \quad \text{and} \quad \{E'_1, \dots, E'_n\}$$

of X into cells so that each E_i maps to E'_i by a cellular map.

Piecewise-Cellular Theorem (B–Forrest 2025)

If the metric on X is undistorted, then any piecewise-cellular homeomorphism of X is a quasisymmetry.

Constructing Quasisymmetries

A homeomorphism of X is **piecewise-cellular** if there exist subdivisions

$$\{E_1, \dots, E_n\} \quad \text{and} \quad \{E'_1, \dots, E'_n\}$$

of X into cells so that each E_i maps to E'_i by a cellular map.

Piecewise-Cellular Theorem (B–Forrest 2025)

If the metric on X is undistorted, then any piecewise-cellular homeomorphism of X is a quasisymmetry.

This generalizes Lyubich and Merenkov's result that every element of the basilica Thompson group is a quasisymmetry of the basilica.

Constructing Quasisymmetries

We can use this theorem to prove that individual Julia sets have lots of quasisymmetries.

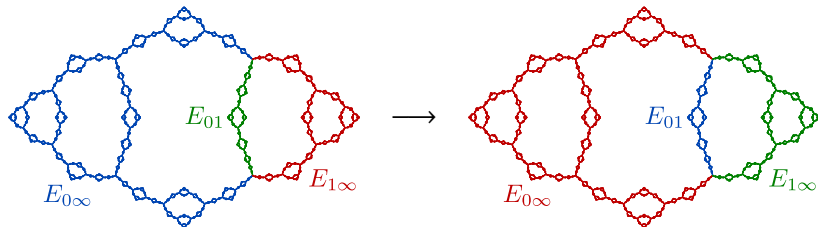

Constructing Quasisymmetries

We can use this theorem to prove that individual Julia sets have lots of quasisymmetries.

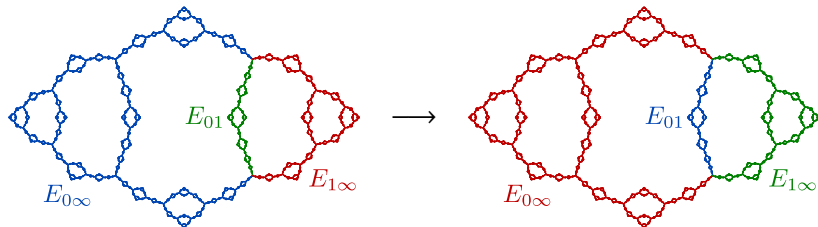

Theorem (B–Forrest 2025)

The quasisymmetry group of the Julia set for $f(z) = \frac{1}{z^2} - 1$ contains $\mathbb{Z}_3 * \mathbb{Z}_2$.

Constructing Quasisymmetries

But some finitely ramified Julia sets have only finitely many quasisymmetries.

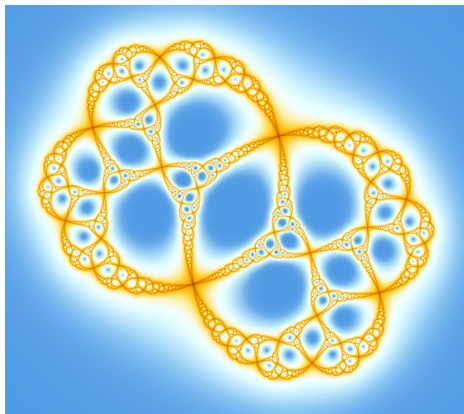

$$\text{Julia set for } f(z) = \frac{e^{2\pi i/3} z^2 - 1}{z^2 - 1}$$

Constructing Quasisymmetries

But some finitely ramified Julia sets have only finitely many quasisymmetries.

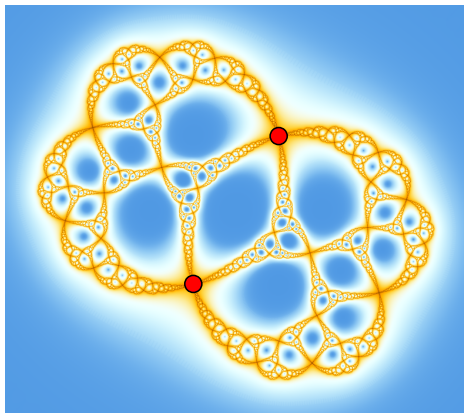

$$\text{Julia set for } f(z) = \frac{e^{2\pi i/3} z^2 - 1}{z^2 - 1}$$

Constructing Quasisymmetries

But some finitely ramified Julia sets have only finitely many quasisymmetries.

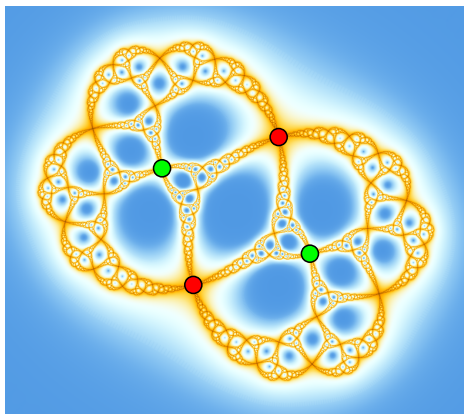

$$\text{Julia set for } f(z) = \frac{e^{2\pi i/3} z^2 - 1}{z^2 - 1}$$

Polynomials

Quadratic Polynomials

Theorem (B–Forrest 2025)

Any connected Julia set for a hyperbolic quadratic polynomial has infinitely many quasisymmetries.

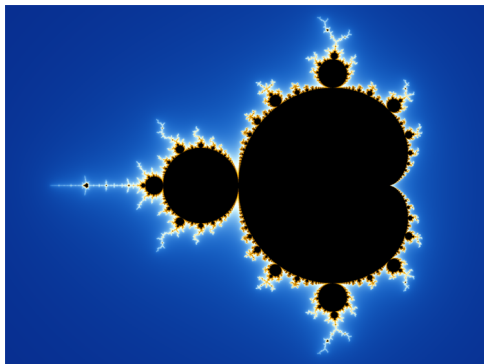

Quadratic Polynomials

Theorem (B–Forrest 2025)

Any connected Julia set for a hyperbolic quadratic polynomial has infinitely many quasisymmetries.

Quadratic Polynomials

Theorem (B–Forrest 2025)

Any connected Julia set for a hyperbolic quadratic polynomial has infinitely many quasisymmetries.

We have **two** proofs of this theorem:

1. We prove that the quasisymmetry group contains $\mathbb{Z}_2 * \mathbb{Z}_n$ for some $n \geq 2$.
2. We also prove that the quasisymmetry group contains Thompson's group F .

The two proofs generalize to different classes of higher-degree polynomials. For example, (1) generalizes to any hyperbolic unicritical polynomial with connected Julia set.

Making $\mathbb{Z}_2 * \mathbb{Z}_n$

Making $\mathbb{Z}_2 * \mathbb{Z}_n$

A fixed point for a polynomial f is **rotational** if it is the landing point for a nontrivial cycle of external rays.

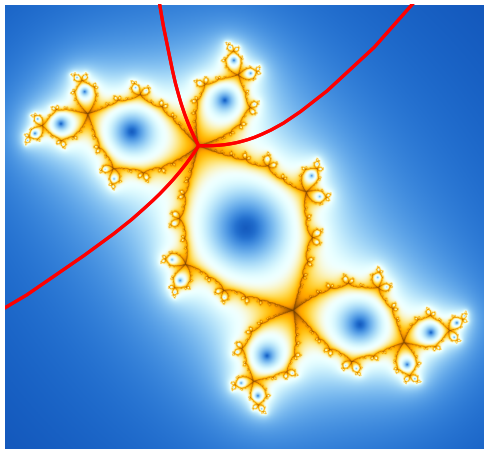

Making $\mathbb{Z}_2 * \mathbb{Z}_n$

If the critical points are in the right place, we can define a **rotation** at such a point.

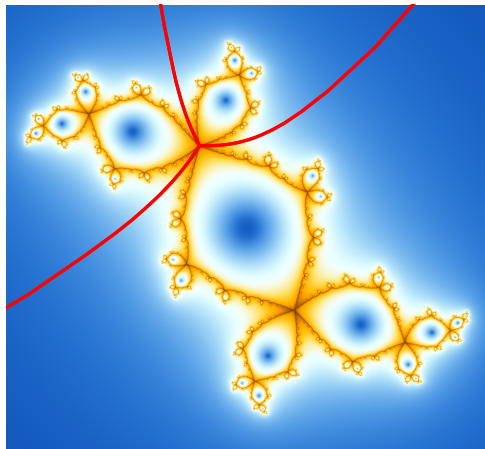

Making $\mathbb{Z}_2 * \mathbb{Z}_n$

If the critical points are in the right place, we can define a **rotation** at such a point.

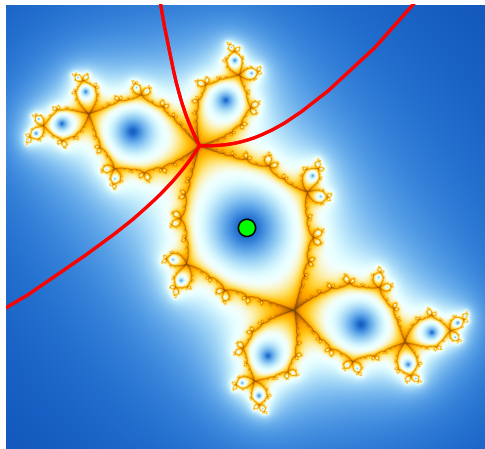

Making $\mathbb{Z}_2 * \mathbb{Z}_n$

If the critical points are in the right place, we can define a **rotation** at such a point.

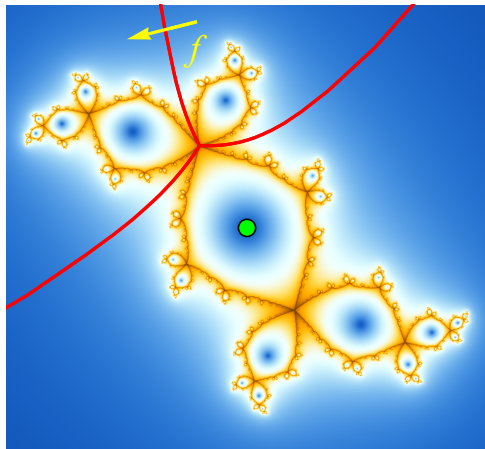

Making $\mathbb{Z}_2 * \mathbb{Z}_n$

If the critical points are in the right place, we can define a **rotation** at such a point.

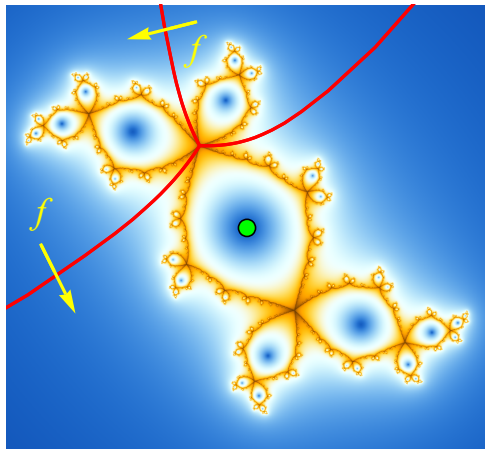

Making $\mathbb{Z}_2 * \mathbb{Z}_n$

If the critical points are in the right place, we can define a **rotation** at such a point.

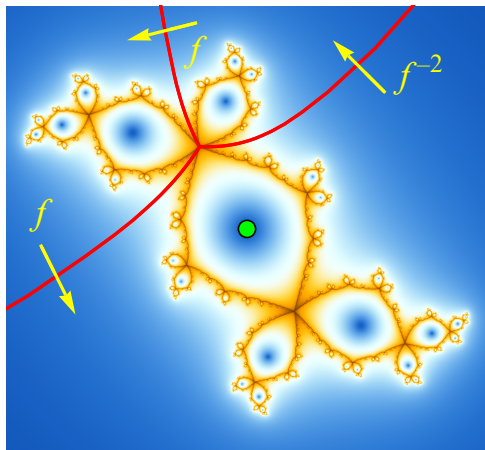

Making $\mathbb{Z}_2 * \mathbb{Z}_n$

Quadratics always have a rotational fixed point, as well as 180° rotational symmetry around the critical point.

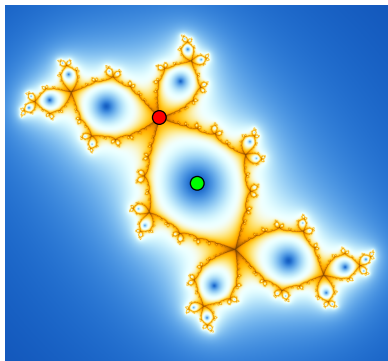

contains $\mathbb{Z}_2 * \mathbb{Z}_3$

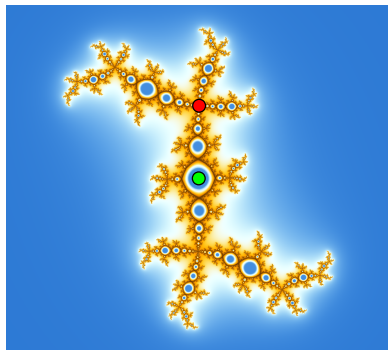

contains $\mathbb{Z}_2 * \mathbb{Z}_4$

Making $\mathbb{Z}_2 * \mathbb{Z}_n$

Quadratics always have a rotational fixed point, as well as 180° rotational symmetry around the critical point.

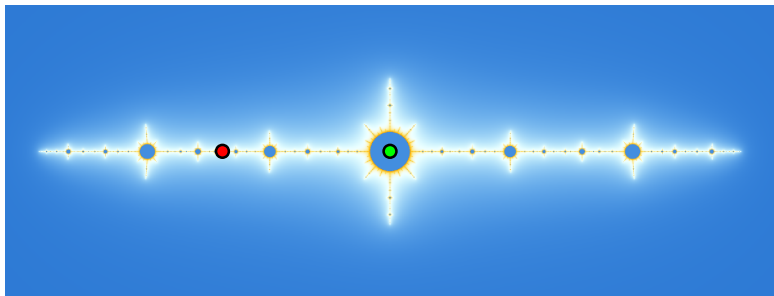

contains $\mathbb{Z}_2 * \mathbb{Z}_2$

Making $\mathbb{Z}_2 * \mathbb{Z}_n$

Quadratics always have a rotational fixed point, as well as 180° rotational symmetry around the critical point.

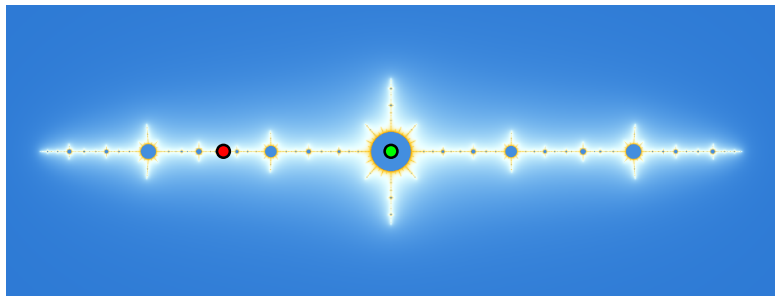

contains $\mathbb{Z}_2 * \mathbb{Z}_2$

The isomorphism with the free product follows from a ping-pong argument.

Higher Degree

This argument actually works for unicritical polynomials of any degree. You get $\mathbb{Z}_d * \mathbb{Z}_n$, where d is the degree.

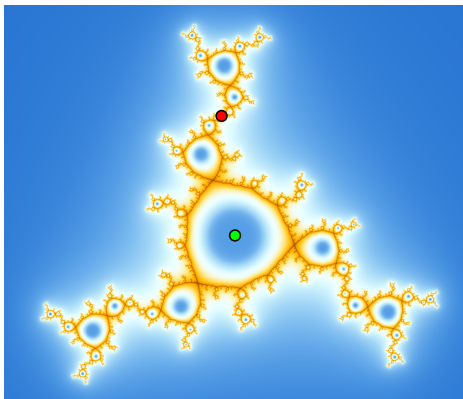

contains $\mathbb{Z}_3 * \mathbb{Z}_2$

Making Thompson's Group F

Making Thompson's Group F

Thompson's group F is the stabilizer of 0 in Thompson's group T .

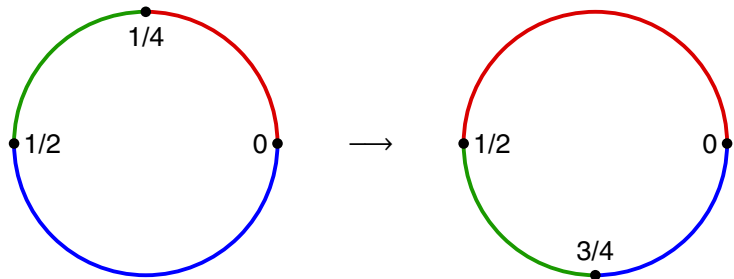

Making Thompson's Group F

Making Thompson's Group F

For a quadratic polynomial, we make a copy of F based at the Fatou component that contains the critical value.

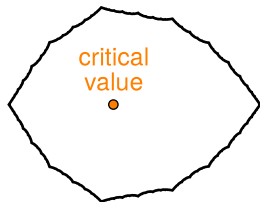

Making Thompson's Group F

For a quadratic polynomial, we make a copy of F based at the Fatou component that contains the critical value.

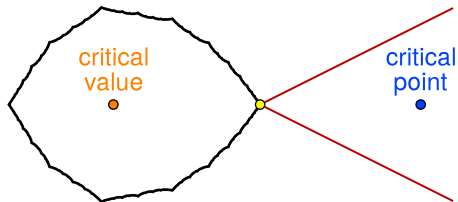

Making Thompson's Group F

For a quadratic polynomial, we make a copy of F based at the Fatou component that contains the critical value.

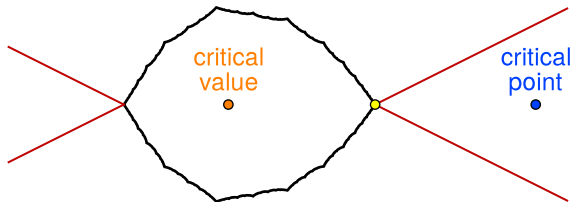

Making Thompson's Group F

For a quadratic polynomial, we make a copy of F based at the Fatou component that contains the critical value.

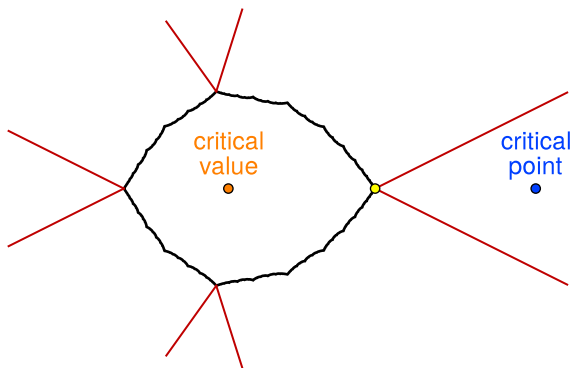

Making Thompson's Group F

For a quadratic polynomial, we make a copy of F based at the Fatou component that contains the critical value.

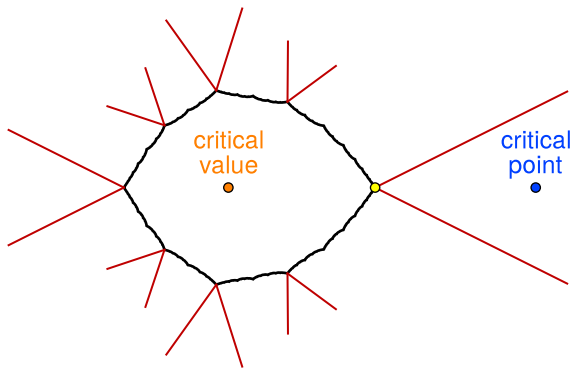

Making Thompson's Group F

For a quadratic polynomial, we make a copy of F based at the Fatou component that contains the critical value.

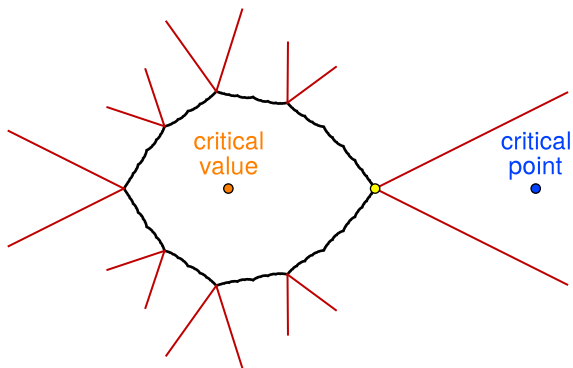

This argument works whenever a leaf of the Hubbard tree lies in a critical cycle of degree two.

Cubic Polynomials

Milnor (1992) classifies hyperbolic cubic polynomials into four types. In the postcritically finite case, these are:

- A. Unicritical polynomials.
- B. Two critical points in the same cycle.
- C. One critical point in a cycle, the other pre-periodic.
- D. Two critical points in two different cycles.

Cubic Polynomials

Milnor (1992) classifies hyperbolic cubic polynomials into four types. In the postcritically finite case, these are:

- A. Unicritical polynomials.
- B. Two critical points in the same cycle.
- C. One critical point in a cycle, the other pre-periodic.
- D. Two critical points in two different cycles.

Connected Julia sets of types (A) and (D) always have infinitely many quasisymmetries.

Cubic Polynomials

Milnor (1992) classifies hyperbolic cubic polynomials into four types. In the postcritically finite case, these are:

- A. Unicritical polynomials.
- B. Two critical points in the same cycle.
- C. One critical point in a cycle, the other pre-periodic.
- D. Two critical points in two different cycles.

Connected Julia sets of types (A) and (D) always have infinitely many quasisymmetries.

We suspect that there are Julia sets of types (B) and (C) with only finitely many quasisymmetries.

An Cubic Polynomial of Type (B)

As far as we know, this Julia set only has one nontrivial quasisymmetry.

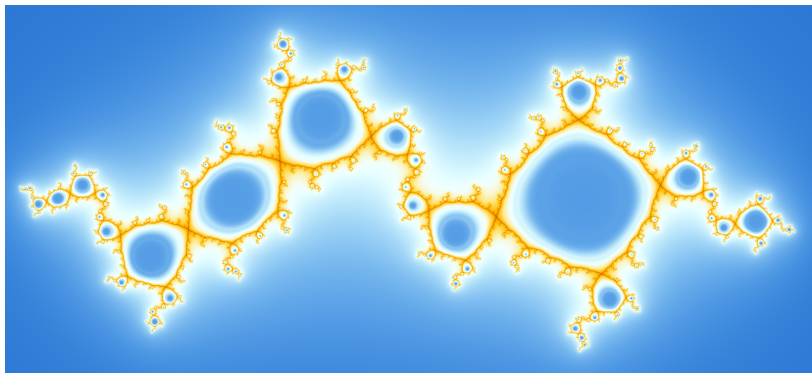

Julia set for $f(z) = (4.424 + 1.374i)(z^3 - 3z + 2) - 1$

An Cubic Polynomial of Type (B)

As far as we know, this Julia set only has one nontrivial quasisymmetry.

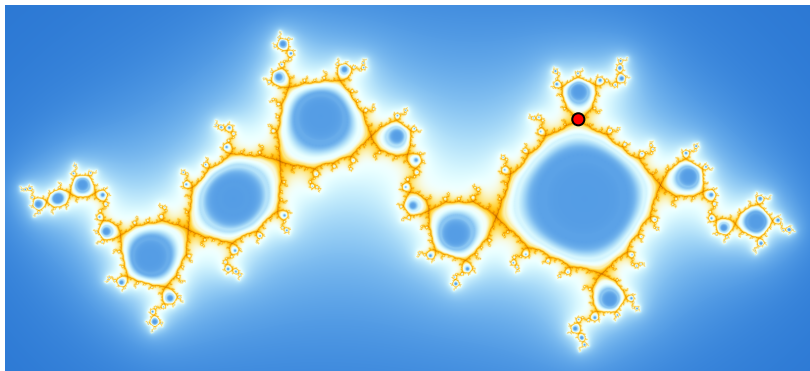

Julia set for $f(z) = (4.424 + 1.374i)(z^3 - 3z + 2) - 1$

The End